



Tel: 800.285.0666 | sales@wastequip.com
www.galbreathproducts.com

OR-Models

LEGACY (U-SERIES)

ROLL OFF CABLE HOISTS

CAPACITIES: 25K LBS. TO 80K LBS.

MODELS: U2/U3/U4/U5/U75/U80-OR

Outside Rail (OR) roll-off cable hoists are the most commonly used models in the industry. They are also among the most versatile hoists still being used today. The OR-models are equipped with outside rollers that allow the container long sills to transition across the hoist frame without friction of metal on metal.



Standard Features

- Inside air controls mounted in ergonomic power tower featuring Plug And Play™ wiring
- Back-up alarm & hoist up alarm with signal light in cab
- Secondary manual controls mounted outside on driver's side
- Outside frame rail stationary rear container hold downs
- Steel hydraulic tank side mounted with 3 micron filtration, dual sight/temp. gauge & air breather
- 10" Grease grooved cable sheaves
- Heavy-duty cast ductile iron rear hinge
- Automatic spring loaded pass through front container lock
- 4" O.D. Side rollers with bronze bearings
- Auto fold air assist ICC bumper
- Pintle adaptable rear apron & bumper assembly with DOT approved LED lighting
- Mid body LED turn signal lights
- Dual hoist maintenance / safety props
- Warranty: Limited lifetime on frame & 2-year limited on hydraulic system
- Customized engineering layouts ensure the best fit for each customer

FEATURE	SINGLE AXLE	TANDEM AXLE
Hoist main frame	8" x 3" x 3/8" – A500 Grade C tubing	8" x 4" x 1/2" – A500 Grade C tubing
Hoist sub frame	4" x 3" x 1/4" – A500 Grade C tubing	3" x 2" x 3/16" – A500 Grade C tubing
Hydraulic pump	Gear type 21 GPM @ 1,500 RPM (nominal)	Gear type 42 GPM @ 1,500 RPM (nominal)
Operating pressure	1,850 PSI	1,850 PSI (1,950 PSI U75/80)
Hydraulic valve	2 Spool / 25 GPM with safety bypass	2 Spool / 45 GPM with safety bypass
Oil reservoir	17-gallon steel tank with 3 micron return filtration system	50-gallon steel tank with 3 micron return filtration system
Lift cylinders	(2) Dual acting rod type	(2) Dual acting rod type 3-stage tel. - UT/UH/U75T models
Hinge shaft	1 1/2" Solid steel	2 1/2" Solid steel
Winch cylinders	(2) Dual acting rod type	(2) Dual acting rod type
Cable/ cable end	5/8" Steel cable / pear eye cable end	7/8" Steel cable (1" on U80) / Swivel cable end
Cable sheaves	10" Grease grooved	10" Grease grooved
Cable anchors	(4) Cable clamps	(4) Cable clamps
Front stop	1 1/2" Steel plate	1 1/2" Steel plate
Front safety lock	Automatic spring loaded	Automatic spring loaded



Steel hydraulic tank side mounted with 3 micron filtration, dual sight/temp. gauge & air breather



4" O.D. Side rollers w/ bronze bushings; outboard supported standard 75k lbs. and up models



Inside air controls in power tower or integrated into center console on cab over trucks; Secondary outside manual controls at main control valve



Outside frame rail stationary rear container hold downs



Air assist auto folding ICC bumper



Heavy-duty cast ductile iron rear hinge



Heavy-duty rear apron w/ split bumpers & recessed LED lighting



Signal light in cab

Available Options

- Pioneer® tarping systems
- Tarp and control valve mounting platform
- Steel, aluminum or poly fenders
- Toolbox styles and sizes (poly, steel, aluminum)
- Rear window screen protection
- Lift axles (steer and non-steer)
- Reverse mount lift cylinders (standard on single axle models)
- Telescopic lift cylinders (standard on UT & UH hoist models)
- Auxiliary hydraulic hook ups and wet kits
- Pintle hooks and towing applications
- Auxiliary containers stops and hold downs
- T1 steel wear strips for main frame rails
- Side mounted skid plates
- Hard plumbing
- Various cable ends
- Safety and additional LED work lighting
- Speed limiting parameters for hoist up and ground speed
- Scale systems
- Back-up camera systems



Pioneer® tarping systems



Pintle hooks and wet kits for towing applications



Toolbox styles and sizes (poly, steel, aluminum)



Steel, aluminum or poly fenders



LED work lights



Back-up camera system



Outboard supported side rollers (standard on 75k lb. and up models)



Telescopic lift cylinders



Lift axles (steer and non-steer)



Rear wing skid plates

U5-OR-174 shown with Pioneer® tarping system, poly tandem axle fenders and nylon ratchet rear hold down options.



U5-OR-174 shown with Pioneer® tarp, LED safety lighting, Hi-Vis yellow tail, rear ratchet hold downs, rear window screen, fire extinguisher, and poly tandem axle fender options



U5-OR-174 shown with Pioneer® tarp, front and rear ratchet hold downs, lift axle, and poly tri-axle fender options

OR-Models

Figure 1

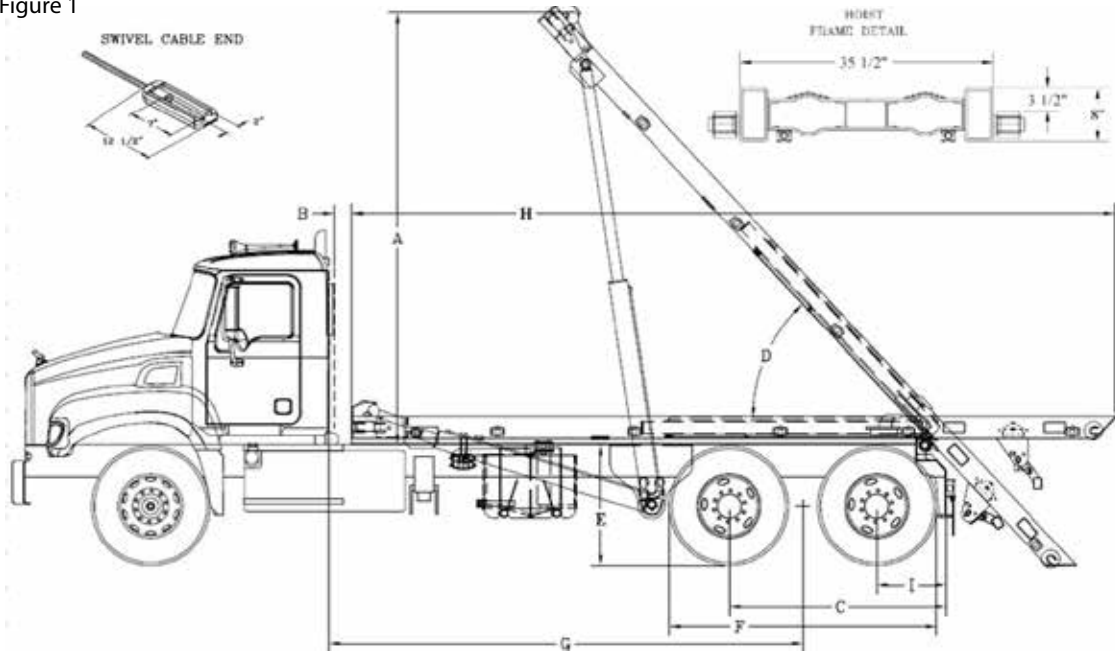

Notes for chart below:

- 1) When recommending container lengths, weight distribution, fender interference and overhang are factors. Please consult your local ordinances when determining the model of hoist needed to suit your container needs.
- 2) Factory tested with recommended container length and water level load.
- 3) Frame Height = top of truck chassis frame to ground. Using 22.5" tires only. For larger tires, consult engineering for clearance.
- 4) This distance does not allow for a behind the cab (BTC) oil reservoir, tarper platform and or room to add a tarper; must add distance for those items.
- 5) Request additional tail length for spring suspensions higher than 45"; see chart 1 for reference.

Specifications	U2-OR-138	U3-OR-156	U3-OR-178	U4-OR-174	U5-OR-174	UT-OR-174
Recommended container size ¹	14' to 18'	14' to 18'	18' to 22'	18' to 22'	18' to 22'	18' to 22'
Rated hoist capacity ²	25,000 lbs.	30,000 lbs.	30,000 lbs.	40,000 lbs.	60,000 lbs.	60,000 lbs.
A – Height above frame ^{3 5}	143 7/8"	156 3/4"	162 3/8"	162 3/8"	162 3/8"	162 3/8"
B – Back of cab to hoist ⁴	6"	6"	6"	6"	6"	6"
C – Axle spread	n/a	n/a	n/a	51" - 55"	51" - 55"	51" - 55"
D – Raised dump angle ³	51°	51°	48°	48°	48°	48°
E – Top of truck frame to ground ^{3 5}	42"	42"	42"	44"	44"	44"
F – Tire O.D. to O.D.	n/a	n/a	n/a	96" max.	96" max.	96" max.
G – Cab to trunnion (CT) Add 12" for tarper & hard plumbing	138"	156"	178"	174"	174"	174"
H – Hoist length ⁵	236"	246"	274 3/4"	279 7/16"	279 7/16"	279 7/16"
I – After frame (Add 2" for air ride)	36 3/4"	37 1/4"	36 3/4"	23" - 25"	23" - 25"	23" - 25"
Lift Cylinders (reverse mount on single axle models standard)	5" x 3" x 54"	5" x 3" x 54"	5" x 3" x 66"	6" x 4 1/2" x 72"	6" x 4" x 72"	n/a
Lift Cylinders telescopic cylinders standard on UT/UH-models)	n/a	n/a	n/a	n/a	n/a	6"-5"-4" x 118"
Winch cylinders	5" x 3" x 66"	5" x 3" x 66"	6" x 3" x 75"	6" x 3" x 80"	7" x 4" x 80"	7" x 4" x 80"
Approx. weight with standard features Ship out weight, un-mounted	4,863 lbs.	5,900 lbs.	6,106 lbs.	6,908 lbs.	6,955 lbs.	6,955 lbs.

Minimum Truck Requirements (Single Axle - U2-Models)

Axle rating: 8,000 front / 18,000 rear
Truck torque: 212' lbs.

*The chart below is an example of how to calculate the chassis section modulus (RBM/PSI = SM). Regardless of the frame YIELD and RBM, the min. SM must be 10 in³ or more per each frame rail.

Truck Channel Ht.	RBM	Yield (PSI)	RBM/PSI = SM in ³
10" or more (single wall)	1,200,000- 3,000,000	120,000 psi	10 in ³ - 25 in ³
10" or more (double wall)	1,000,000- 3,000,000	100,000 psi	10 in ³ - 30 in ³

Note: The single walled 120k psi with RBM less than 1,200,000 would not be acceptable because its SM would fall below the 10 in³ minimum specification (1,100,000/120,000 = 9.17 in³). For frames less than 10", consult engineering.

Minimum Truck Requirements (Single Axle - U3-Models)

Axle rating: 9,000 front / 24,400 rear
Truck torque: 212' lbs.

*The chart below is an example of how to calculate the chassis section modulus (RBM/PSI = SM). Regardless of the frame YIELD and RBM, the min. SM must be 17.5 in³ or more per each frame rail.

10" or more (single wall)	2,100,000- 3,000,000	120,000 psi	17.5 in ³ - 25 in ³
10" or more (double wall)	1,750,000- 3,000,000	100,000 psi	17.5 in ³ - 30 in ³

Note: The single walled 120k psi with RBM less than 2,400,000 would not be acceptable because its SM would fall below the 17.5 in³ minimum specification (2,000,000/120,000 = 16.67 in³). For frames less than 10", consult engineering.

Minimum Truck Requirements (Tandem Axle)

Axle rating: 18,000 front / 44,000 rear
Truck torque: 261' lbs.

*The chart below is an example of how to calculate the chassis section modulus (RBM/PSI = SM). Regardless of the frame YIELD and RBM, the min. SM must be 17.5 in³ or more per each frame rail.

Truck Channel Ht.	RBM	Yield (PSI)	RBM/PSI = SM in ³
10" or more (single wall)	2,400,000- 4,000,000	120,000 psi	20 in ³ - 33.3 in ³
10" or more (double wall)	2,000,000- 4,000,000	100,000 psi	20 in ³ - 40 in ³

Note: The single walled 120k psi with RBM less than 2,400,000 would not be acceptable because its SM would fall below the 20 in³ minimum specification (2,300,000/120,000 = 19.17 in³). For frames less than 10", consult engineering.

TRUCK FRAME HEIGHT & TAIL LENGTH CHART

Frame Height (Inches)		Tail Length measured from center of rear hinge to tip of tail	
MIN.	MAX.	Added Length	Total Length
42"	44 ½"	0 inches - Std.	69 ¾"
45"	47 ½"	4"	73 ¾"
48"	50 ½"	8"	77 ¾"
51"	53 ½"	12"	81 ¾"
54"	56 ½"	12"	81 ¾"

Round to the nearest inch

Cycle Times @ 1,850 PSI & 1,500 RPM

Hoist Up -	25 sec.
Hoist Down -	14 sec.
Winch On -	38 sec.
Winch Off -	26 sec.

*U5-OR-174 theoretical times shown

U5-OR-194	UT-OR-194	U75-OR-174	U75T-OR-174	U75-OR-194	U75T-OR-194	U80-OR-194	U80T-OR-194
20' to 24'	20' to 24'	18' to 22'	18' to 22'	20' to 24'	20' to 24'	20' to 24'	20' to 24'
60,000 lbs.	60,000 lbs.	75,000 lbs.	75,000 lbs.	75,000 lbs.	75,000 lbs.	80,000 lbs.	80,000 lbs.
178 ¾"	178 ¾"	162 ¾"	162 ¾"	178 ¾"	178 ¾"	178 ¾"	178 ¾"
6"	6"	6"	6"	6"	6"	6"	6"
51" - 55"	51" - 55"	51" - 55"	51" - 55"	51" - 55"	51" - 55"	51" - 55"	51" - 55"
48°	48°	48°	48°	48°	48°	48°	48°
44"	44"	44"	44"	44"	44"	44"	44"
96" max.	96" max.	96" max.	96" max.	96" max.	96" max.	96" max.	96" max.
194"	194"	174"	174"	194"	194"	194"	194"
299 ¼"	299 ¼"	279 ⅞"	279 ⅞"	299 ¼"	299 ¼"	299 ¼"	299 ¼"
23" - 25"	23" - 25"	23" - 25"	23" - 25"	23" - 25"	23" - 25"	23" - 25"	23" - 25"
6" x 4" x 72"	n/a	7" x 4" x 72"	n/a	7" x 4" x 72"	n/a	7" x 4" x 72"	n/a
n/a	6"-5"-4" x 118"	n/a	6"-5"-4" x 118"	n/a	6"-5"-4" x 118"	n/a	6"-5"-4" x 118"
7" x 4" x 90"	7" x 4" x 90"	7" x 4" x 80"	7" x 4" x 80"	7" x 4" x 90"	7" x 4" x 90"	7" x 4" x 90"	7" x 4" x 90"
7,300 lbs.	7,300 lbs.	7,500 lbs.	7,500 lbs.	7,720 lbs.	7,720 lbs.	7,790 lbs.	7,790 lbs.

Extendable Tail Models

EX Series

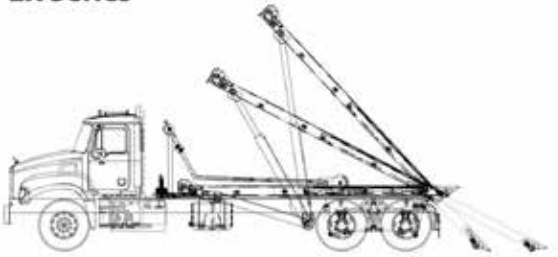

Essentially a shortened OR-model with a 80" extendable tail section that generates low loading angles and has 35.5 inch rail width.

IX Series

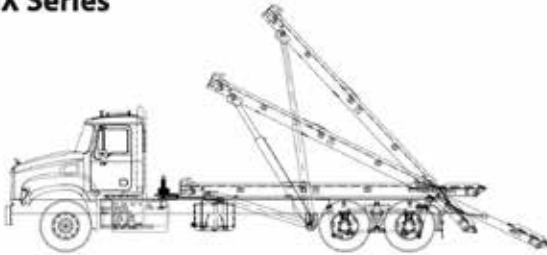

An OR/EX-model extendable tail (60") with both inside and outside rails and rollers. The hoist has set rail widths of 35.5 inches.

EH Series

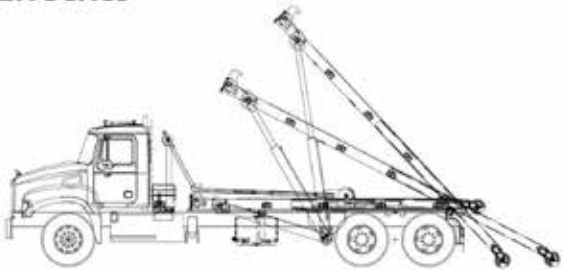

A combination of an EX & HH-model, designed for picking up dead lift containers at low loading angles with an 80" extendable tail section. This hoist has a narrower rail width set at 35 inches.

OX Series

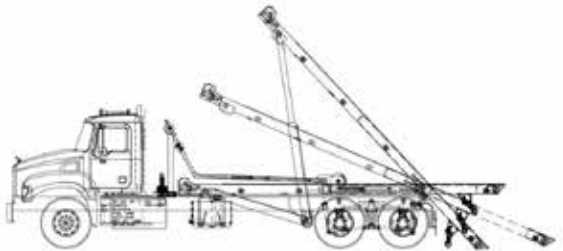

An OR-style hoist with a tail that is extendable out to an additional 48". The hoist has set rail widths of 35.5 inches.

Fixed Tail Models

OR Series



The OR-model (industry standard) is an outside/inside rail and roller hoist set at 35.5 inches wide between rails.

IO Series

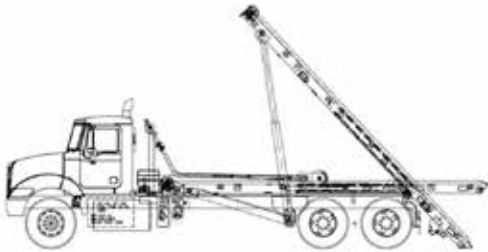

Similar to the OR-model, the IO-model has additional inside rollers (inside of main frame tubes) and inside rails fixed to the top of main frame. The hoist is set at 35.5 inches wide between rails.

HH Series



HH - A shortened and narrowed version of the OR-model that is designed to pick up deadlift containers with a knuckle cable end. The hoist rails are set at 35 inches wide.

SI Series

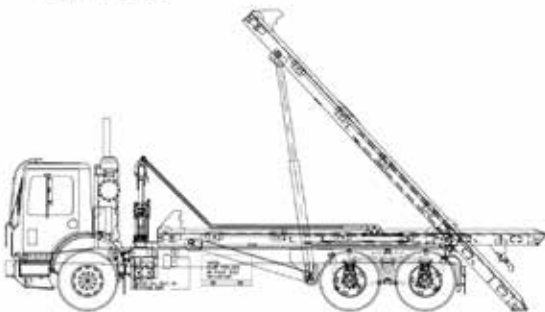

A cross breed of sorts, the SI-model is unique in the fact that it is designed to pick up a variety of different styles of containers. Specifically, it will pick up either outside rail, inside/outside rail and deadlift containers. The hoist is set at 35 inches.

TM Series

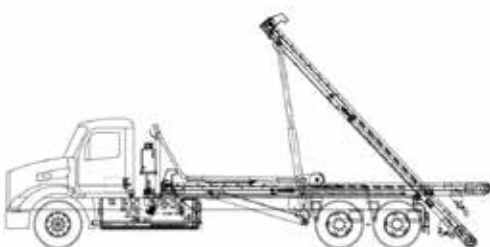

A representative of a unique market sector of the Pacific Northwest, the TM-model (Trough Mount) is typically a hoist that utilizes a trough section on either side to support the containers as opposed to rollers or rails. Many different variations exist for its dimensions and can be adapted to suit most consumer requirements.

Container Rear Hold Down Locations (Dimension "X")

DIM. 'X' GALBREATH REAR HOLD DOWN SETTING

145 1/2" +1/-0"
for CONTAINERS >= 12 FT TO 14 FT

149" +1/-0"
for CONTAINERS >= 14 FT TO 16 FT

173" +1/-0"
for CONTAINERS >= 16 FT TO 18 FT

191" +1/-0"
for CONTAINERS 18 FT & LONGER

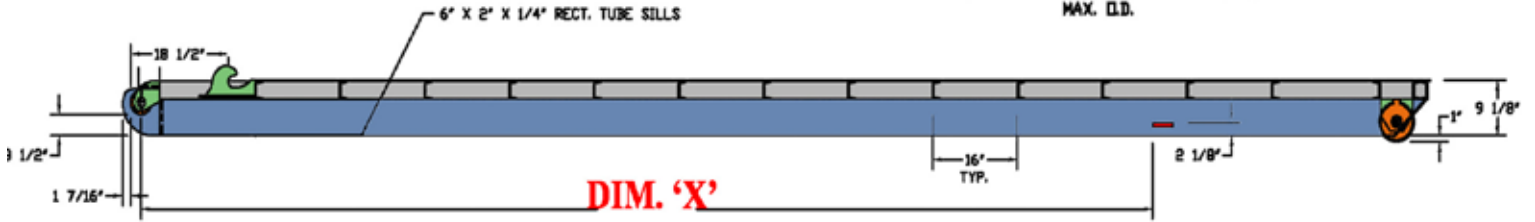
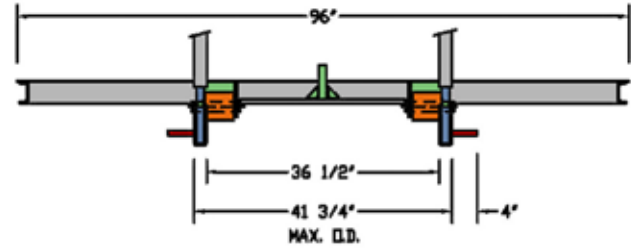

Distributed by:



Galbreath is a Wastequip brand. Wastequip is the leading North American manufacturer of waste and recycling equipment for collecting, processing and transporting recyclables and solid or liquid waste. © Wastequip 2017 All rights reserved. Specifications subject to improvement without notice. Equipment displayed should be operated by properly trained personnel. Operators should become familiar with OSHA, ANSI and any other applicable standards or laws for using this equipment. Improper use, misuse, or lack of maintenance could cause injury to people and/or property. Photos used in the literature are illustrative only. We assume no liability or responsibility for proper training/operation of equipment not manufactured by Wastequip. We reserve the right to make changes at any time without notice. Information contained within this literature is intended to be the most accurate available at time of printing.

GAL063-072018